

*RELAY*bility



RELAYS

ROLLING STOCK
APPLICATIONS



SHORT-FORM
CATALOG

Efficient infrastructures deserve



Energy HV Transmission

Rolling Stock

only the most reliable components



Railway Infrastructures

Energy Production

THE COMPANY IN BRIEF

Electromechanical relays manufacturer for **energy applications** (power plants and T&D), rolling stock, railway industry, **Italian production and development** since 1975.

Relays' **center of excellence** and competence of the CHAUVIN ARNOUX group.

The company is proficient in manufacturing high reliability relays and available to engineer **custom solutions** with a lean approach and an agile company structure.

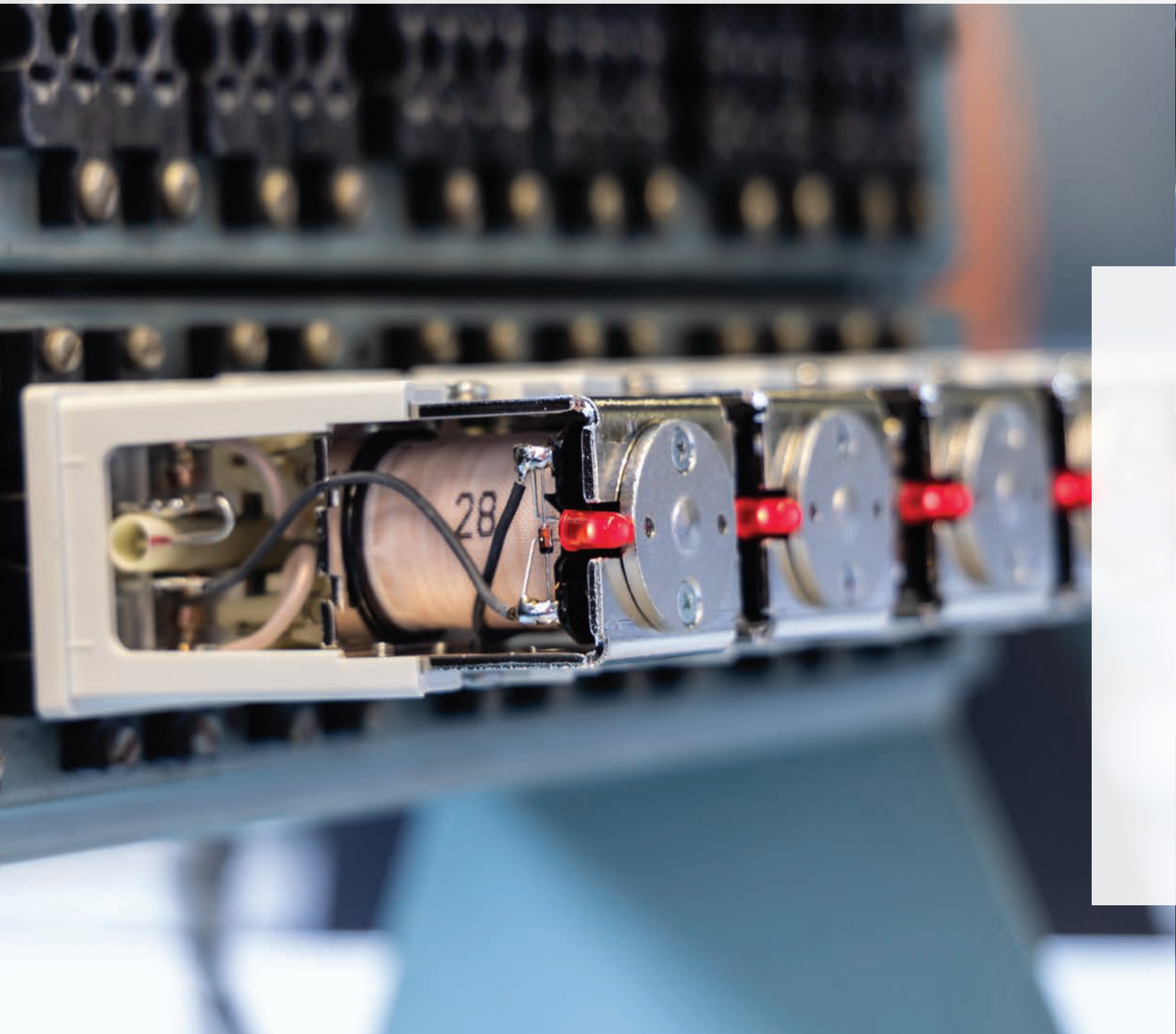

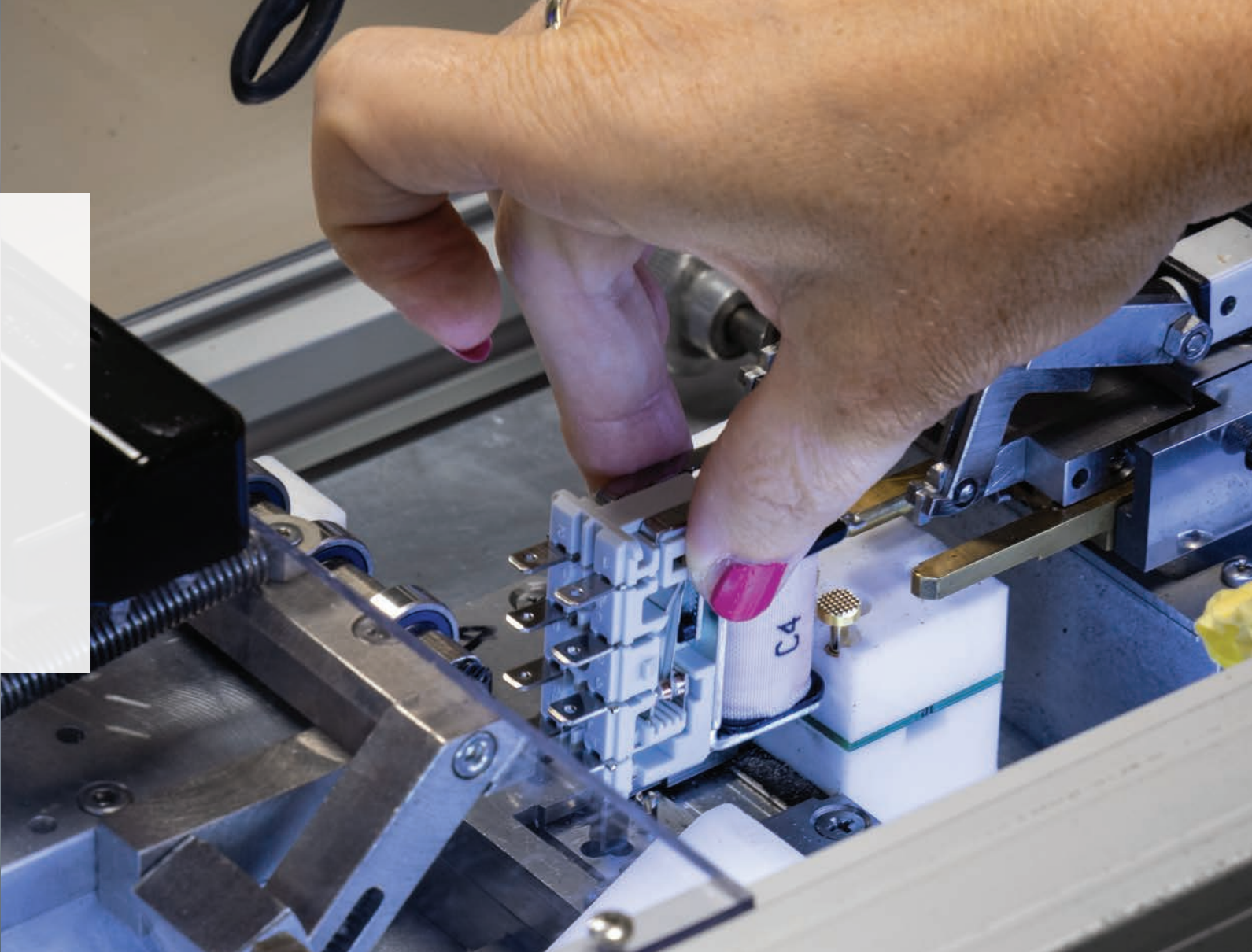

METICULOUS PROCESSES LEAD TO RELIABLE COMPONENTS

The materials, the design and in general the construction engineering processes make AMRA relays of **heavy-duty** construction and highly suitable for use in demanding applications.

For instance, during the construction phases,

all the contacts of each individual relay are accurately checked.

This is to ensure reliable operations even when the contacts must conduct a very **low current**.

To be sure that every contact is **perfectly calibrate**, a **conductivity and pressure test** are carried-out **on each contact**.

At the end of the production cycle, every single relay **is put under test which foresee the execution of hundreds operations**. This aims to verify that each relay and each contact works perfectly.



MAIN APPLICATIONS

The **AMRA relays** have been successfully used for **over 40 years** on the major platforms and can be considered of **proven reliability** for:

- High speed trains, **EMUs**, **ETRs** and in general standard coaches and locomotives;
- **Trams**, **driverless metros** and in general **underground trains**.

COMPLIANT WITH INTERNATIONAL STANDARDS

IEC 61810-1	Electromechanical Elementary Relay
IEC 60077-2	Electric equipment for rolling stock - electro technical components
EN 50155	Electronic equipment used on rolling stock
IEC 61373	Shock and vibration tests, Category 1, Class B
EN 45545-2	Fire behaviour, Category E10, Requirement R26, V0
ASTM E162, E662	Fire behaviour
BSS 7239	Fire behaviour

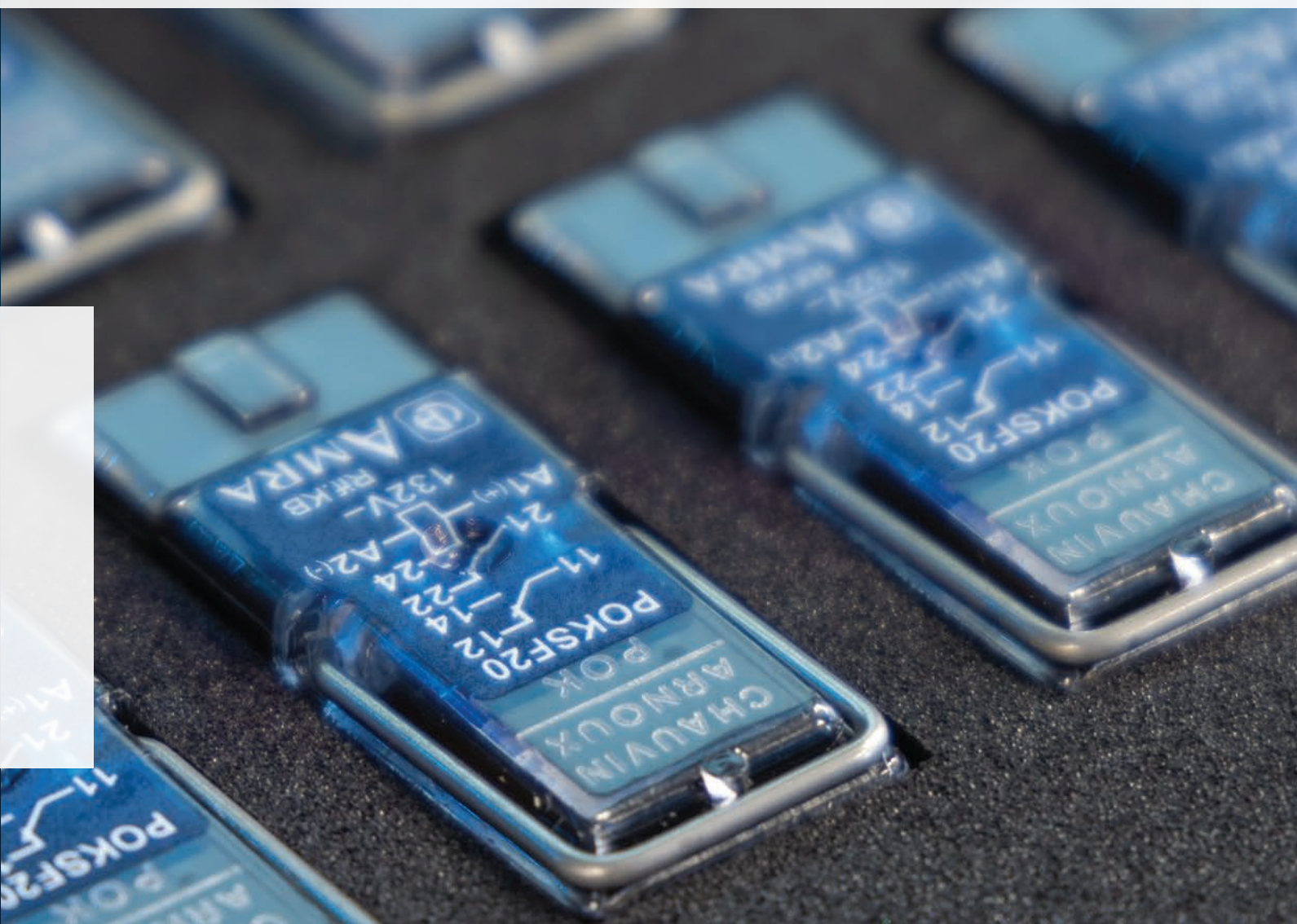



OUR CATALOGUES AND APPROVALS

ENEL | TERNA APPROVED SERIES

Enel (Italian DSO) and **TERNA** (Italian TSO) have approved **AMRA** relays for electricity production, HV transmission and MV/LV distribution networks. This range is compliant with the specifications **LV15**, **LV16**, **LV20**, and designed for heavy use in control, protection, monitoring and automation systems.

RFI APPROVED SERIES

Relays for railway infrastructure systems, approved by the Italian railway network operator (RFI), compliant with the technical specification **RFI DPRIM STF TE 143 A**.





This range is designed for use in electrical substations and electrical traction systems.

ENERGY SERIES

Standard auxiliary relays, lock-out and trip relays designed to meet the highest level of reliability in the most demanding sectors (energy production and T&D, railway infrastructure and rolling stock). Adopted globally by the main operators, system integrators and cabinet manufacturers.

Index

Models

10 >	Compact Instantaneous Monostable	POKS BIPOKS TRIPOKS QUADRIPOKS	
12 >	Instantaneous Monostable	OKUIC	
14 >	Instantaneous Latching	OKBA	
16 >	Time Lag	OKT TM TMM	
16 >	Timer Unit	UTM	
18 >	Measuring with Voltage Threshold	MOK-V2	
20 >	About Forcibly Guided Contacts	<i>Write-Up</i>	
22 >	Compact Instantaneous Monostable	RCG RDG	
24 >	Instantaneous Monostable	RGG RMGX	
26 >	Time lag, multiscale	RGK	
28 >	Direct Current Neutral	RGMZ63X	
32 >	Sockets		

WELD-NO-TRANSFER

COMPACT PLUG-IN MONOSTABLES INSTANTANEOUS RELAYS



POKS 2 C/O



BIPOKS 4 C/O



TRIPOKS 6 C/O

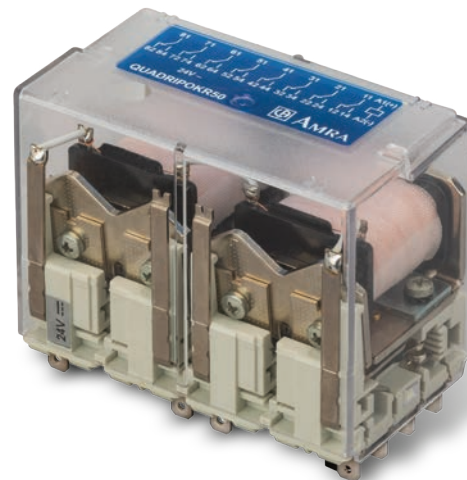

QUADRIPOKS 8 C/O

OVERVIEW

- Solid and rugged construction for heavy or intensive duty
- Independent and self-cleaning contacts
- Magnetic arc blow-out as standard
- Separate arc breaking chambers



DATASHEET

PLUS OF THE RELAY RANGE

Designed in 1972, the POK relay whose name originates in “Petite OK”, was born as a **series of high-performance relays with small dimensions.**

This series totally represents the core values of the company and the constructive objectives that it sets itself: to create electromechanical components that are able to achieve the maximum **reliability**, and that are suitable for use in **severe operating environments**, covering roles with **the highest responsibility for intervention.**

Peculiarity of this relay model is the absence of connection braids and soldering on the contact terminals.

MODELS	POKS	BIPOKS	TRIPOKS	QUADRIPOKS
Number of contacts	2 C/O	4 C/O	6 C/O	8 C/O
COIL DATA				
Nominal voltages Un - Standard	DC: 12-24-36-48-72-96-110-125-132-144-230 (Other values on request)			
Operating range (rolling stock)	DC: 70...125% Un			
Max. consumption at Un (DC/AC)	2.5W	3W	3.5W	6W
Type of duty	Continuous			
CONTACT DATA				
Number and type of contacts	2 SPDT, Form C	4 SPDT, Form C	6 SPDT, Form C	8 SPDT, Form C
Current				
Nominal	10 A			
Maximum peak (1 min)	20 A			
Maximum pulse (10 ms)	150 A			
Minimum load				
Standard contacts	500 mW (20V, 20mA)			
Gold-plated contact P8	50 mW (5V, 5mA)			
NOTE: Values referred to a new product, measured in laboratory. The ability to maintain this performance over the time depends on the environmental conditions and the contact' frequency use. The use of gold plated contacts is recommended in the case of very low loads. For a correct use please see product datasheet.				
Maximum breaking voltage	250 Vdc / 350 Vac			
Example of electrical life expectancy				
Standard contacts	0.5 A - 110 Vdc - L/R 40 ms : 10 ⁵ operations			
Cadmium contacts + Neodymium	1 A - 125 Vdc - L/R 40 ms : 10 ⁵ operations			
Operating time at Un (ms) including bounces				
Pick-up (NO contact closing)	≤ 20	≤ 25	≤ 25	≤ 25
Drop-out (NC contact closing)	≤ 15	≤ 20	≤ 20	≤ 20
GENERAL DATA				
Dimensions (mm) - terminals excluded	20 x 50 x 45	40 x 50 x 45	60 x 50 x 45	80 x 61 x 45
Weight (g)	90	170	250	340
Mechanical life expectancy	DC: 20 x 10 ⁶			
Insulation resistance (at 500Vdc)	> 1,000 MΩ			
Withstand voltage at industrial frequency				
Between electrically independent circuits and between these circuits and ground	2 kV (1 min) - 2.2 kV (1 s)			
Between open contact parts	1 kV (1 min) - 1.1 kV (1 s)			
Between adjacent contacts	2.5 kV (1 min) - 3 kV (1 s)			
Operating temperature	Standard: -25 ÷ +70°C Low temperature (option): -50 ÷ +70°C			
Resistance to vibrations	5g - 10 ÷ 55 Hz - 1 min			
Resistance to shock	20g - 11 ms			
Relative humidity	Standard: 75% RH Tropicalized: 95% RH			
Standards	IEC 61810-1, EN 61810-7, EN 60695-2-10, EN 61000, EN 60529, EN 60077, EN 50155, IEC 61373, EN 45545-2, ASTM E162, ASTM E662			

MAIN OPTIONS AND CONFIGURATIONS AVAILABLE

- ▶ Tropicalization of coil (P2): this treatment also protects the coil against corrosion which could occur by combination of the humidity with certain chemical agents
- ▶ Cadmium contacts (P7): AgCdO (silver cadmium oxide) contacts.
- ▶ Gold-plated contacts (P8): Gold plating contacts.
- ▶ Cadmium contacts + Neodymium (P9): AgCdO (silver cadmium oxide) contacts with Neodymium magnetic arc blow-out
- ▶ Led indicator showing presence of power supply.
- ▶ Overvoltage protection: FLYBACK DIODE (Polarized component), VARISTOR or TRANSIL.

SOCKETS

48BIP20-I DIN



DATASHEET



Front screw connection

PAIR160



DATASHEET



Front spring connection

PRIR160



DATASHEET



Rear spring connection

ADF2



DATASHEET



Rear double faston connection

INSTANTANEOUS MONOSTABLES RELAYS



DATASHEET

OKUIC 4 C/O

OVERVIEW

- Solid and rugged construction for heavy or intensive duty
- Very high electrical life expectancy and exceptional endurance
- Patented operating mechanism, designed to ensure high contact pressure
- Independent and self-cleaning contacts with high breaking capacity

PLUS OF THE RELAY RANGE

The OK series relays use a unique and **patented movement mechanism**, which minimize the friction and achieves a **mechanical life of 100,000,000 operations**.

While the stroke of the core is deliberately reduced, **the movement of the contacts is amplified thanks to a system of levers** capable of spacing the contacts up to over **1,2 mm**.

This distance makes it possible to guarantee an voltage impulse withstand greater than **5 kV** between the poles of the same contact.

High mechanical performance, are followed by excellent electrical performance that allows it to be used in the most critical applications in the rolling stock.

MODELS	OKUIC
Number of contacts	4 C/O
COIL DATA	
Nominal voltages Un - Standard	DC: 12-24-36-48-72-96-110-125-132-144-230 (Other values on request)
Operating range (rolling stock)	DC: 70...125% Un
Max. consumption at Un (DC/AC)	3.5W
Type of duty	Continuous
CONTACT DATA	
Number and type of contacts	4 SPDT, Form C
Current	
Nominal	10 A
Maximum peak (1 min)	20 A
Maximum pulse (10 ms)	150 A
Minimum load	
Standard contacts	500 mW (20V, 20mA)
Gold-plated contact	200 mW (20V, 5mA)
NOTE: Values referred to a new product, measured in laboratory. The ability to maintain this performance over the time depends on the environmental conditions and the contact' frequency use. The use of gold plated contacts is recommended in the case of very low loads. For a correct use please see product datasheet.	
Maximum breaking voltage	350 Vdc / 440 Vac
Example of electrical life expectancy	
Standard contacts	0.7 A – 132 Vdc – L/R 40 ms : 10 ⁵ operations
Operating time at Un (ms) including bounces	
Pick-up (NO contact closing)	≤ 40
Drop-out (NC contact closing)	≤ 18
GENERAL DATA	
Dimensions (mm) - terminals excluded	45 x 45 x 109
Weight (g)	280
Mechanical life expectancy	100 x 10 ⁶ operations
Insulation resistance (at 500Vdc)	> 1,000 MΩ
Withstand voltage at industrial frequency	
Between electrically independent circuits and between these circuits and ground	2 kV (1 min) - 2.2 kV (1 s)
Between open contact parts	
Between adjacent contacts	
Operating temperature	Standard: -25 ÷ +70°C Low temperature (option): -40 ÷ +70°C (only for OKBA model)
Resistance to vibrations	5g - 10 ÷ 55 Hz - 1 min
Resistance to shock	30g - 1 ms
Relative humidity	Standard: 75% RH Tropicalized: 95% RH
Standards	IEC 61810-1, EN 61810-2, EN 61810-7, EN 60695-2-10, EN 61000, EN 60529, EN 60077, EN 50155, IEC 61373, EN 45545-2, ASTM E162, ASTM E662

MAIN OPTIONS AND CONFIGURATIONS AVAILABLE

- ▶ Tropicalization of coil (P2): this treatment also protects the coil against corrosion which could occur by combination of the humidity with certain chemical agents
- ▶ Gold-plated contacts (P4 GEO): Gold plating contacts.
- ▶ Led indicator showing presence of power supply.
- ▶ Overvoltage protection: FLYBACK DIODE (Polarized component), VARISTOR or TRANSIL.

SOCKETS

48BIP20-I DIN



DATASHEET



Front screw connection

PAIR160



DATASHEET



Front spring connection

PRIR160



DATASHEET



Rear spring connection

ADF2



DATASHEET



Rear double faston connection

INSTANTANEOUS LATCHING RELAYS



DATASHEET

OKBA 4 C/O

OVERVIEW

- Solid and rugged construction for heavy or intensive duty
- Very high electrical life expectancy and exceptional endurance
- Patented operating mechanism, designed to ensure high contact pressure
- Independent and self-cleaning contacts with high breaking capacity
- Automatic de-energization, energy saving

PLUS OF THE RELAY RANGE

The OK series relays use a unique and **patented movement mechanism**, which minimize the friction and achieves a **mechanical life of 100,000,000 operations**.

While the stroke of the core is deliberately reduced, **the movement of the contacts is amplified thanks to a system of levers** capable of spacing the contacts up to over **1,2 mm**.

This distance makes it possible to guarantee an voltage impulse withstand greater than **5 kV** between the poles of the same contact.

High mechanical performance, are followed by excellent electrical performance that allows it to be used in the most critical applications in the rolling stock.

MODELS	OKBA
Number of contacts	4 C/O
COIL DATA	
Nominal voltages Un - Standard	DC: 12-24-36-48-72-96-110-125-132-144-230 (Other values on request)
Operating range (rolling stock)	DC: 70...125% Un
Max. consumption at Un (DC/AC)	12.5W (latch) / 5.5W (unlatch)
Type of duty	Continuous
CONTACT DATA	
Number and type of contacts	4 SPDT, Form C
Current	
Nominal	10 A
Maximum peak (1 min)	20 A
Maximum pulse (10 ms)	150 A
Minimum load	
Standard contacts	500 mW (20V, 20mA)
Gold-plated contact	200 mW (20V, 5mA)
NOTE: Values referred to a new product, measured in laboratory. The ability to maintain this performance over the time depends on the environmental conditions and the contact' frequency use. The use of gold plated contacts is recommended in the case of very low loads. For a correct use please see product datasheet.	
Maximum breaking voltage	350 Vdc / 440 Vac
Example of electrical life expectancy	
Standard contacts	0.5 A – 110 Vdc – L/R 40 ms : 10 ⁵ operations
Operating time at Un (ms) including bounces	
Pick-up (NO contact closing)	≤ 30
Drop-out (NC contact closing)	≤ 40
GENERAL DATA	
Dimensions (mm) - terminals excluded	45 x 45 x 109
Weight (g)	300
Mechanical life expectancy	20 x 10 ⁶ operations
Insulation resistance (at 500Vdc)	> 1,000 MΩ
Withstand voltage at industrial frequency	
Between electrically independent circuits and between these circuits and ground	2 kV (1 min) - 2.2 kV (1 s)
Between open contact parts	
Between adjacent contacts	
Operating temperature	Standard: -25 ÷ +70°C Low temperature (option): -40 ÷ +70°C (only for OKBA model)
Resistance to vibrations	1g - 5 ÷ 55 Hz - 1 min
Resistance to shock	3g
Relative humidity	Standard: 75% RH Tropicalized: 95% RH
Standards	IEC 61810-1, EN 61810-2, EN 61810-7, EN 60695-2-10, EN 61000, EN 60529, EN 60077, EN 50155, IEC 61373, EN 45545-2, ASTM E162, ASTM E662

MAIN OPTIONS AND CONFIGURATIONS AVAILABLE

- ▶ Tropicalization of coil (P2): this treatment also protects the coil against corrosion which could occur by combination of the humidity with certain chemical agents
- ▶ Gold-plated contacts (P4 GEO): Gold plating contacts.
- ▶ Led indicator showing presence of power supply.
- ▶ Overvoltage protection: FLYBACK DIODE (Polarized component), VARISTOR.

SOCKETS

48BIP20-I DIN



DATASHEET



Front screw connection

PAIR160



DATASHEET



Front spring connection

PRIR160



DATASHEET



Rear spring connection

ADF2



DATASHEET



Rear double faston connection

TIMER RELAYS AND TIMER UNIT



DATASHEET

UTM 4 C/O

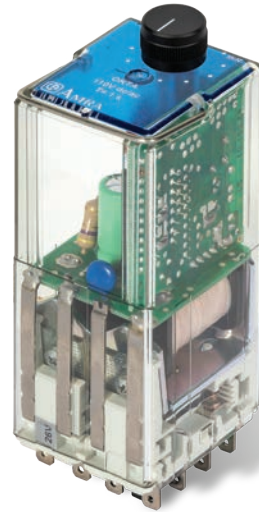

DATASHEET

OKT 4 C/O

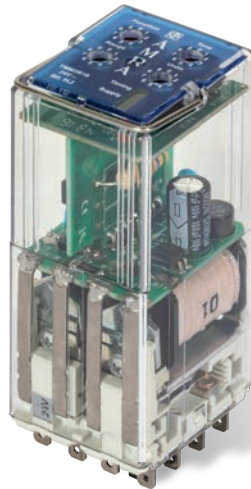

DATASHEET

TMM 4 C/O

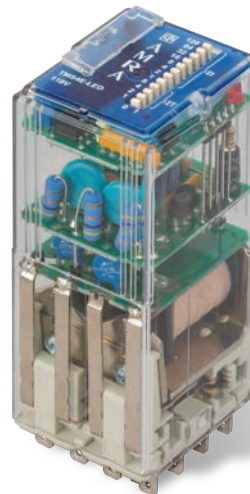

DATASHEET

TMS 4 C/O

OVERVIEW

- **UTM:** static timer unit, operating on pick-up or drop-out
- **TMM:** multifunction, timed, plug-in relay
- **TMS, OKT:** time delay relay, pick-up or drop-out
- Wide time setting range: from 0.1 to 99 hours, multiscale
- High EMC immunity

PLUS OF THE RELAY RANGE

The electromechanical part features has the same **reliability** and **ruggedness** of the POK series.

The PCB design aims to offer the highest reliability as well, thanks to the use of professional and components. The timer function, the scale and the switching time are adjustable by means of 4 rotary switches, or dip switch.

The **design and construction procedures can ensure a wide electrical life** and **high reliability** level also in harsh operating environments or with strong temperature fluctuations.

MODELS	OKT	TMS	TMM	UTM
Number of contacts	4 C/O	TMS4: 4 C/O TMS2: 2+2 (instantaneous) C/O	TMM4: 4 C/O TMM2: 2+2 (instantaneous) C/O	2 Outputs
COIL DATA				
Nominal voltages Un - Standard	DC: 12-24-36-48-72-96-110-125-132-144-230 (Other values on request)			DC: 24-36-72-110-128
Operating range (rolling stock)	DC: 70...125% Un			DC: 80...115% Un
Max. consumption at Un (DC/AC)	4 W		TMM4: 4,5W TMM2: 5,5W	0,6 W
Type of duty	Continuous			
CONTACT DATA				
Number and type of contacts	4 SPDT, Form C	4 SPDT, Form C 2+2 instantaneous SPDT, Form C	TMM4: 4 SPDT, Form C TMM2: 2+2 instantaneous SPDT, Form C	1 instantaneous output 1 timed output
Current				
Nominal	5 A	10 A	10 A	-
Maximum peak (1 min)	10 A	20 A	20 A	
Maximum pulse (10 ms)	100 A	150 A	150 A	
Maximum power at output				6 W
Minimum load				
Standard contacts	500 mW (20V, 20mA)			
Gold-plated contact P8	50 mW (5V, 5mA)			
NOTE: Values referred to a new product, measured in laboratory. The ability to maintain this performance over the time depends on the environmental conditions and the contact frequency use. The use of gold plated contacts is recommended in the case of very low loads. For a correct use please see product datasheet.				
Maximum breaking voltage	250 Vdc / 350 Vac			
Example of electrical life expectancy				
Standard contacts	0.5 A – 110 Vdc – L/R 40 ms : 10 ⁵ operations		0.7 A – 132 Vdc – L/R 40 ms : 10 ⁵ operations	
Operating time at Un (ms) including bounces				
Pick-up (NO contact closing)	≤ 20	≤ 20	≤ 20	-
Drop-out (NC contact closing)	≤ 15	≤ 15	≤ 15	
GENERAL DATA				
Dimensions (mm) - terminals excluded	40 x 45 x 97			40 x 40 x 50
Weight (g)	220			60
Mechanical life expectancy	20 x 10 ⁶ operations			-
Insulation resistance (at 500Vdc)	> 1,000 MΩ			
Withstand voltage at industrial frequency				
Between electrically independent circuits and between these circuits and ground	2 kV (1 min) - 2.2 kV (1 s)			
Between open contact parts	1 kV (1 min) - 1.1 kV (1 s)			-
Between adjacent contacts	2.5 kV (1 min) - 3 kV (1 s)			
Operating temperature	Standard: -25 ÷ +70°C	Standard: -25 ÷ +70°C Low temperature (option): -50 ÷ +70°C	Standard: -25 ÷ +70°C	Standard: -25 ÷ +70°C Low temperature (option): -50 ÷ +70°C
Resistance to vibrations	5g - 10 ÷ 55 Hz - 1 min			
Resistance to shock	20g - 11 ms			
Relative humidity	Standard: 75% RH Tropicalized: 95% RH			Standard: 75% RH
Standards	IEC 61810-1, EN 61810-2, EN 61810-7, EN 61812-1, EN 60695-2-10, EN 61000, EN 60529, EN 60077 EN 50155, IEC 61373, EN 45545-2, ASTM E162, ASTM E662, CU TR 011/2011			
TIME SETTING				
Function	pick-up or drop-out	pick-up or drop-out	multifunction	pick-up or drop-out
Full scale time	from 1 s to 60 min	32,768 s	99 h	32,768 s
Setting	potentiometer	DIP switch	4 rotary switches	DIP switch

MAIN OPTIONS AND CONFIGURATIONS AVAILABLE

- ▶ Tropicalization of coil (P2): this treatment also protects the coil against corrosion which could occur by combination of the humidity with certain chemical agents.
- ▶ Cadmium contacts (P7): AgCdO (silver cadmium oxide) contacts.
- ▶ Gold-plated contacts (P8): Gold plating contacts.
- ▶ Led indicator showing presence of power supply.
- ▶ Overvoltage protection: FLYBACK DIODE (Polarized component), VARISTOR or TRANSIL.

SOCKETS

48BIP20-I DIN



DATASHEET



Front screw connection

PAIR160



DATASHEET



Front spring connection

PRIR160



DATASHEET



Rear spring connection

ADF2



DATASHEET



Rear double faston connection

VOLTAGE MEASURING RELAY WITH ADJUSTABLE HYSTERESIS



DATASHEET

MOK-V2

2
C/O

OVERVIEW

- Pick-up and drop-out thresholds adjustable by two independent potentiometers
- Solid and rugged construction for heavy or intensive duty
- Excellent shock and vibration resistance

PLUS OF THE RELAY RANGE

Products of the **MOK** series are measuring relays with **adjustable hysteresis**.

The **MOK-V2** is a measuring relay with two adjustable voltage thresholds: Pick-up voltage and Drop-out voltage.

The pick-up voltage can be set at between 60% and 120% of nominal voltage.

The drop-out voltage can be set at between 70% and 98% of the pick-up voltage.

MODELS	MOK-V2			
Number of contacts	4 C/O			
COIL DATA				
Nominal voltages Un - Standard	DC: 24-36-48-72-110-125-132-144-220			
Max. consumption at Un (DC/AC)	3,5 W			
Type of duty	Continuous			
OPERATING THRESHOLDS				
Setting	By way of potentiometers, with flat head slotted screw			
Pick-up threshold	$V(i) = 60\% \div 120\% U_n$			
Drop-out threshold	$V(r) = 70\% \div 98\% V(i)$			
Functional diagram	MOKV2x1 (Standard)		MOKV2x9 (Fast-acting)	
1 Pick-up delay (closing of the NO contact) ⁽¹⁾	Vi = 60%	Vi = 80...100%	Vi = 60%	Vi = 80...100%
	relay powered 0.05...1.9 s relay not powered 0.5...2.7 s	relay powered 0.8...4 s relay not powered 1...4 s	relay powered 0.05...0.2 s relay not powered 0.5...0.8 s	relay powered 0.07...0.2 s relay not powered 0.5...0.8 s
2 Drop-out delay (closing of the NC contact) ⁽¹⁾	0.2...3.5 s		0.25...2 s	
Electronic reset time in case of power failure	≤ 3 s @ V < 5% Un		≤ 0,7 s @ V < 5% Un	
Attention: the drop-out voltage Vr is expressed as a percentage of the pick-up voltage. ⁽¹⁾ Tolerances on time indicated: 10%.				
CONTACT DATA				
Number and type of contacts	2 SPDT, Form C			
Current				
Nominal	8 A			
Minimum load	100 mW (10V, 5mA)			
Maximum breaking voltage	150 Vdc / 440 Vac			
Example of electrical life expectancy				
Standard contacts	0,2 A – 110 Vdc – L/R 40 ms : 10 ⁵ operations			
GENERAL DATA				
Dimensions (mm) - terminals excluded	48x 48x 118,5			
Weight (g)	180			
Mechanical life expectancy	10 x 10 ⁶ operations			
Insulation resistance (at 500Vdc)	> 1,000 MΩ			
Withstand voltage at industrial frequency				
Between electrically independent circuits and between these circuits and ground	2 kV (1 min) - 2,2 kV (1 s)			
Between open contact parts	1 kV (1 min) - 1,1 kV (1 s)			
Operating temperature	Standard: -25 ÷ +70°C			
Relative humidity	Standard: 75% RH Tropicalized: 95% RH			
Standards	IEC 61810-1, EN 61810-2, EN 61810-7, EN 60695-2-10, EN 61000, EN 60529, EN 60077, EN 50155, IEC 61373, EN 45545-2, ASTM E162, ASTM E662			

MAIN OPTIONS AND CONFIGURATIONS AVAILABLE

- ▶ Tropicalization of coil (P2): this treatment also protects the coil against corrosion which could occur by combination of the humidity with certain chemical agents.

SOCKETS

48BIP20-I DIN



DATASHEET



Front screw connection

PAIR160



DATASHEET



Front spring connection

PRIR160



DATASHEET



Rear spring connection

ADF2



DATASHEET



Rear double faston connection

FORCIBLY GUIDED CONTACTS

Relays with forcibly guided contacts are used in safety circuits. These kind of contacts are mechanically linked.



WELD-NO-TRANSFER

6 MODELS FROM 2 TO 8 CONTACTS

- **RCG** 2 C/O contacts
- **RDG** 4 C/O contacts
- **RGG** 4 C/O contacts, 12 A
- **RMGX** 6 C/O + 2 NO contacts
- **RGK** 4 C/O time-delay contacts
- **RGMZ63X** 4 C/O contacts

These relays are equipped with mechanically linked contacts (forcibly guided), an indispensable feature for applications where there is a need to guarantee that make (NO) contacts will never assume the same status as break (NC) contacts.

Forcibly guided contacts are also known as WELD-NO-TRANSFER contacts.



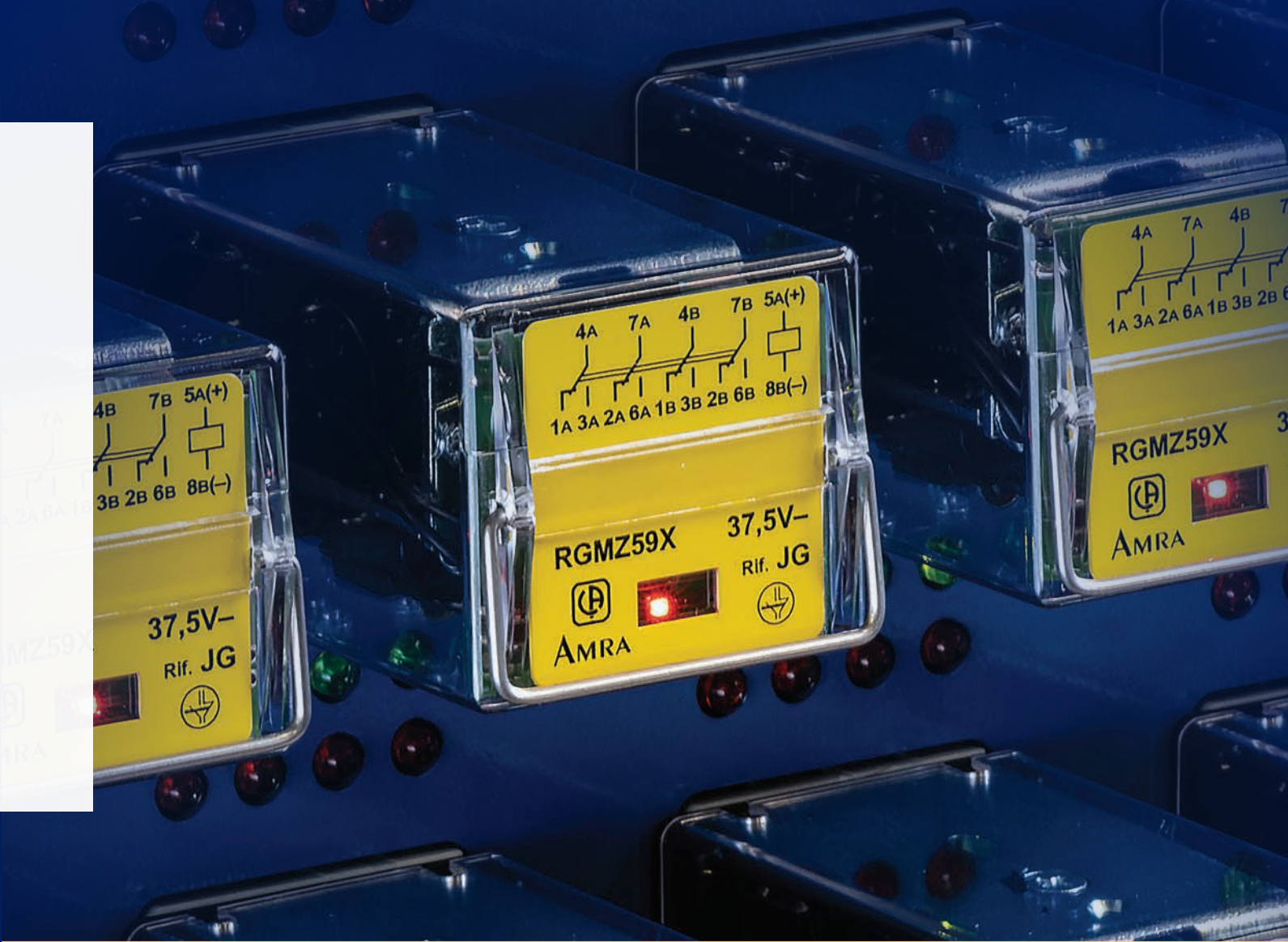

PURPOSE

TESTING ACCORDING TO IEC 61810-3, TYPE A: CONTACTS ARE ALL MECHANICALLY LINKED

There are some intrinsic features that can help designers to obtain a greater level of safety in a project using electromechanical relays compliant with IEC 61810-3 type A.

Using relays with forcibly guided contacts (a.k.a. mechanically linked or weld-no-transfer), the designers can be sure that the make (NO) contacts will never assume the same status as the break (NC) contacts.

With this feature, any supervision control system can read the actual status of the relays' contacts at anytime and with absolute certainty.

With forcibly guided technology any contact's fault can be identified and properly managed for safety purposes.

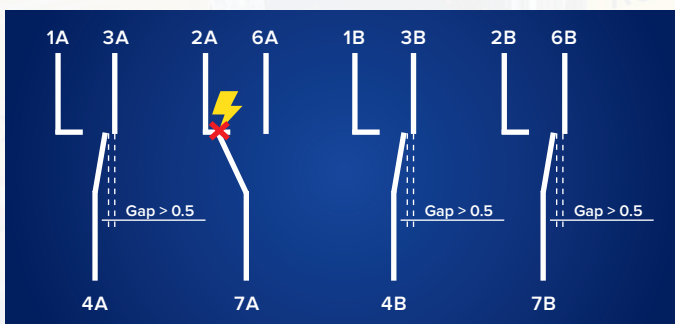

COMPACT RELAYS WITH FORCIBLY GUIDED CONTACTS



RCG 2 C/O



RDG 4 C/O



WELD- NO-TRANSFER

OVERVIEW

- Forcibly guided (mechanically linked) contacts
- Compliance with IEC 61810-3, type A
- Suitable for safety applications
- Self-cleaning knurled contacts, C/O type



DATASHEET

PLUS OF THE RELAY RANGE

RCG & RDG relay, with 2 & 4 changeover contacts, are highly reliable products featuring high performance, suitable for applications in very harsh and disturbed environments, such as **ROLLING STOCK** applications.

The contacts are designed to obtain remarkable performances both for high, inductive loads or very low loads.

In this relay range with forcibly guided contacts (mechanically linked) special design and constructional measures are used to ensure that **make (NO) contacts cannot assume the same state as break (NC) contacts.**

MODELS	RCG	RDG
Number of contacts	2C/O	4C/O
COIL DATA		
Nominal voltages Un - Standard	DC: 24-36-48-72-96-110-125 (Other values on request)	
Operating range (rolling stock)	DC: 70...125% Un	
Max. consumption at Un (DC/AC)	2.2W	2.7W
Type of duty	Continuous	
CONTACT DATA		
Number and type of contacts	2 SPDT, Form C	4 SPDT, Form C
Current		
Nominal	10 A	
Maximum peak (1 min)	20 A	
Maximum pulse (10 ms)	100 A	
Minimum load		
Standard contacts	200 mW (10V, 10mA)	
Gold-plated contact	50 mW (5V, 5mA)	
NOTE: Values referred to a new product, measured in laboratory. The ability to maintain this performance over the time depends on the environmental conditions and the contact' frequency use. The use of gold plated contacts is recommended in the case of very low loads. For a correct use please see product datasheet.		
Maximum breaking voltage	250 Vdc / 300 Vac	
Example of electrical life expectancy		
Standard contacts	0.2 A – 110 Vdc – L/R 40 ms : 5 x 10 ⁵ operations	
With HIGH POWER magnetic arc blow-out	0.7 A – 132 Vdc – L/R 40 ms : 7 x 10 ⁴ operations 600 operations/h	
Operating time at Un (ms) including bounces		
Pick-up (NO contact closing)	≤ 19	≤ 25
Drop-out (NC contact closing)	≤ 16	≤ 14
GENERAL DATA		
Dimensions (mm) - terminals excluded	40 x 20 x 50	40 x 40 x 50
Weight (g)	60	115
Mechanical life expectancy	20 x 10 ⁶ operations	
Insulation resistance (at 500Vdc)	> 1,000 MΩ	
Withstand voltage at industrial frequency		
Between electrically independent circuits and between these circuits and ground	4 kV (1 min)	
Between coil and contact parts	3 kV (1 min)	
Between open contact parts	2 kV (1 min)	
Between adjacent contacts	3,5 kV (1 min)	
Operating temperature	Standard: -25 ÷ +70°C Low temperature (option): -40 ÷ +70°C	
Relative humidity	Standard: 75% RH Tropicalized: 95% RH	
Standards	IEC 61810-1, EN 61810-7, IEC 61810-3 Type A, EN 60695-2-10, EN 61000, EN 60529, EN 60077, EN 50155, IEC 61373, EN 45545-2, ASTM E162, ASTM E662	

MAIN OPTIONS AND CONFIGURATIONS AVAILABLE

- ▶ Tropicalization of coil (T): this treatment also protects the coil against corrosion which could occur by combination of the humidity with certain chemical agents
- ▶ Gold-plated contacts.
- ▶ Led indicator showing presence of power supply.
- ▶ Overvoltage protection: FLYBACK DIODE (Polarized component), or TRANSIL.

SOCKETS

48BIP20-I DIN



DATASHEET



Front screw connection

PAIR160



DATASHEET



Front spring connection

PRIR160



DATASHEET



Rear spring connection

ADF2



DATASHEET



Rear double faston connection

■ RELAYS WITH FORCIBLY GUIDED CONTACTS



RGG 4 C/O



DATASHEET



WELD- NO-TRANSFER



RMGX 6 C/O + 2 NO



DATASHEET

OVERVIEW

- Forcibly guided (mechanically linked) contacts
- Compliance with IEC 61810-3, type A
- Suitable for safety applications
- Self-cleaning knurled contacts, C/O type
- High breaking capacity
- **RMGX**: manual operation (standard)

PLUS OF THE RELAY RANGE

RGG and **RMGX** relay, with 4 & 8 changeover contacts, are highly reliable products featuring high performance, suitable for applications in very harsh and disturbed environments, such as **ROLLING STOCK** applications.

The contacts are designed to obtain remarkable performances both for high, inductive loads or very low loads. Each contact is able to switch from 10mA – 10V without gold-plating the contacts.

MODELS	RGG	RMGX
Number of contacts	4C/O	6C/O + 2 NO
COIL DATA		
Nominal voltages Un - Standard	DC: 24-36-48 - 72-96-110	
Operating range (rolling stock)	DC: 70...125% Un	
Max. consumption at Un (DC/AC)	3 W	
Type of duty	Continuous	
CONTACT DATA		
Number and type of contacts	4 SPDT, Form C	6 SPDT + 2 NO, Form C
Current		
Nominal	12 A	10 A
Maximum peak (1 min)	20 A	20 A
Maximum pulse (10 ms)	150 A	150 A
Minimum load		
Standard contacts	200 mW (10V, 10mA)	
Gold-plated contact	50 mW (5V, 5mA)	
NOTE: Values referred to a new product, measured in laboratory. The ability to maintain this performance over the time depends on the environmental conditions and the contact' frequency use. The use of gold plated contacts is recommended in the case of very low loads.		
Maximum breaking voltage	350 Vdc / 440 Vac	
Example of electrical life expectancy		
Standard contacts	0.5 A – 110 Vdc – L/R 40 ms : 10 ⁵ operations	
With magnetic arc blow-out	1 A – 110 Vdc – L/R 40 ms: 10 ⁵ operations 1,200 operations/h	
Operating time at Un (ms) including bounces		
Pick-up (NO contact closing)	≤ 35	≤ 60
Drop-out (NC contact closing)	≤ 53	≤ 45
GENERAL DATA		
Dimensions (mm) - terminals excluded	45 x 50 x 86	45 x 90 x 100
Weight (g)	280	380
Mechanical life expectancy	10 x 10 ⁶ operations	
Insulation resistance (at 500Vdc)	> 1,000 MΩ	
Withstand voltage at industrial frequency		
Between electrically independent circuits and between these circuits and ground	2 kV (1 min) - 2,2 kV (1 s)	
Between open contact parts		
Between adjacent contacts		
Operating temperature	Standard: -25 ÷ +70°C Low temperature (option): -50 ÷ +85°C	Standard: -25 ÷ +70°C Low temperature (option): -40 ÷ +70°C
Resistance to vibrations	5g - 10 ÷ 60 Hz - 1 min	1g - 5 ÷ 55 Hz - 1 min
Relative humidity	Standard: 75% RH Tropicalized: 95% RH	
Standards	IEC 61810-1, EN 61810-7, IEC 61810-3 Type A, EN 60695-2-10, EN 61000, EN 60529, EN 60077, EN 50155, IEC 61373, EN 45545-2, ASTM E162, ASTM E662	

MAIN OPTIONS AND CONFIGURATIONS AVAILABLE

- ▶ Tropicalization of coil (T): this treatment also protects the coil against corrosion which could occur by combination of the humidity with certain chemical agents
- ▶ Gold-plated contacts: Gold plating contacts.
- ▶ Led indicator showing presence of power supply.
- ▶ Overvoltage protection: FLYBACK DIODE (Polarized component), or TRANSIL.

SOCKETS

48BIP20-I DIN



DATASHEET



Front screw connection

PAIR160



DATASHEET



Front spring connection

PRIR160



DATASHEET



Rear spring connection

ADF2



DATASHEET



Rear double faston connection

MULTISCALE TIME RELAYS WITH FORCIBLY GUIDED CONTACTS



DATASHEET



WELD- NO-TRANSFER

RGK

4
C/O

OVERVIEW

- Forcibly guided (mechanically linked) contacts
- Compliance with **IEC 61810-3, type A**
- Suitable for safety applications
- Self-cleaning knurled contacts, C/O type
- Wide time delay range, from 0.1s to more than 16 hours

PLUS OF THE RELAY RANGE

RGK relay, with 2 & 4 changeover contacts, are highly reliable products featuring high performance, suitable for applications in very harsh and disturbed environments, such as **ROLLING STOCK** applications.

The contacts are designed to obtain remarkable performances both for high, inductive loads or very low loads.

MODELS	RGK
Number of contacts	4C/O time-delayed
COIL DATA	
Nominal voltages Un - Standard	DC: 24-36-48-72-96-110-125
Operating range (rolling stock)	DC: 70...125% Un
Max. consumption at Un (DC/AC)	3.5W
Type of duty	Continuous
CONTACT DATA	
Number and type of contacts	4 SPDT, Form C
Current	
Nominal	12 A
Maximum peak (1 min)	20 A
Maximum pulse (10 ms)	150 A
Minimum load	
Standard contacts	200 mW (10V, 10mA)
Gold-plated contact	50 mW (5V, 5mA)
NOTE: Values referred to a new product, measured in laboratory. The ability to maintain this performance over the time depends on the environmental conditions and the contact' frequency use. The use of gold plated contacts is recommended in the case of very low loads.	
Maximum breaking voltage	350 Vdc / 440 Vac
Example of electrical life expectancy	
Contacts with magnetic arc blow-out as standard	1 A – 110 Vdc – L/R 40 ms : 10 ⁵ operations 1,200 operations/h
Operating time at Un (ms) including bounces	
Pick-up (NO contact closing)	≤ 35
Drop-out (NC contact closing)	≤ 53
GENERAL DATA	
Dimensions (mm) - terminals excluded	45 x 50 x 112
Weight (g)	300
Mechanical life expectancy	10 x 10 ⁶ operations
Insulation resistance (at 500Vdc)	> 1,000 MΩ
Withstand voltage at industrial frequency	
Between electrically independent circuits and between these circuits and ground	2 kV (1 min) - 2,2 kV (1 s)
Between open contact parts	
Between adjacent contacts	
Operating temperature	Standard: -25 ÷ +70°C Low temperature (option): -40 ÷ +70°C
Relative humidity	Standard: 75% RH Tropicalized: 95% RH
Standards	IEC 61810-1, EN 61810-2, EN 61810-7, EN 61812, IEC 61810-3 Type A, EN 61812-1, EN 60695-2-10, EN 61000, EN 60529, IEC 60077, EN 50155, IEC 61373, EN 45545-2, ASTM E162, ASTM E662
TIME SETTING	
Function	timer relay
Full scale time	990 min
Setting	DIP switch, rotary switches

MAIN OPTIONS AND CONFIGURATIONS AVAILABLE

- ▶ Tropicalization of coil (T): this treatment also protects the coil against corrosion which could occur by combination of the humidity with certain chemical agents
- ▶ Gold-plated contacts: Gold plating contacts.
- ▶ Led indicator showing presence of power supply.

SOCKETS

48BIP20-I DIN



DATASHEET



Front screw connection

PAIR160



DATASHEET



Front spring connection

PRIR160



DATASHEET



Rear spring connection

ADF2



DATASHEET



Rear double faston connection

DIRECT CURRENT NEUTRAL RELAYS WITH FORCIBLY GUIDED CONTACTS



WELD- NO-TRANSFER

RGMZ63X

4
C/O

OVERVIEW

- 4 C/O forcibly guided contacts
- Compliance with **EN 50578, type N**
- Compliance with **IEC 61810-3, type A**
- **Drop-out by spring + gravity**
- Weld resistant, knurled and self-cleaning contacts
- Nominal current 10A, max breaking voltage 400Vac
- **Relay with TÜV Certification**

PLUS OF THE RELAY RANGE

Direct current relays intended for safety-related applications have special features in designing and construction to ensure long-lasting and reliable operation, in particular, it has a failure mode which is not intrusive for the system's intrinsic safety. These constructive measures therefore allow to prevent certain typical failures in relay operations.

Conceived from the union of the technical skills of **AMRA** and **HITACHI RAIL STS**, the K series relays (model **RGMZ63X**) are safety relays, with 4 C/O forcibly guided contacts (mechanically linked), weld resistant type, with return to the rest position guaranteed by gravity + return spring.

MODELS	RGMZ63X				
Number of contacts	4 C/O				
COIL DATA	KB1004	KC1004	KD1004	KE2004	KF1004
Nominal voltages Un - Standard (DC)	12	24	48	110 / 132 ⁽³⁾	55
Minimum pick-up voltage	0.65...0.95 Un, depending pre-conditioning period				
Max. operating voltage	1.25 Un, continuous				
Type of duty	C / continuous				
Operating temperature range	-25°C ÷ +70°C				
Power, consumption at Un ⁽¹⁾	< 2.5W				
Current, consumption at Un ⁽¹⁾	200 mA	100 mA	50 mA	45 mA	23/19 mA
Minimum pick-up voltage (Ve) ⁽¹⁾	≤ 8.5 V	≤ 19 V	≤ 33.2 V	≤ 40 V	≤ 83.5 / 92.5 V
Maximum release voltage (Vd) ⁽¹⁾⁽²⁾	≥ 5 V	≥ 11 V	≥ 19.8 V	≥ 24 V	≥ 49 / 54.5 V
Release ratio (k) (Vd/Ve) ⁽¹⁾	≥ 0.6				

⁽¹⁾ Data is referred to ambient temperature: 20°C, relay without pre-energization.

⁽²⁾ Specified values are guaranteed for operating voltage range 0.9 ... 1.10 Un.

⁽³⁾ 132Vdc nominal voltage can be obtained by on socket wiring (see "wiring diagram").

CONTACT DATA

Number and type of contacts	4 SPDT, Form C, weld resistant				
Current					
Nominal	@ 1.00 Un, 70°C: 10A - 8A on all contacts simultaneously @ 1.25 Un, 70°C: 7A - 5.6A on all contacts simultaneously				
Overload	20A for 1min - 40A for 1s				
Weld resistance - test	CEI EN61000-4-5 Induced lightning current, type 8/20 μs, 3,000A RFI TCSSTB SF IS 21 756 A Capacitor discharge 500μF, 500Vdc, on NC & NO contacts Test reps: 10, every 30 seconds Measured peak current: 15,900 A for 65 μs				
Contact resistance	< 30 mΩ (initial)				
Example of electrical life ⁽¹⁾	0.5A - 110Vdc - L/R 40ms - 105 operations (1,200 oper/h)				
Minimum load	24Vdc, 10mA				
Maximum switching voltage	400 Vac				
Operating time at Un (ms) ⁽²⁾					
Pick-up (NO contact closing)	≤ 60				
Drop-out (NC contact closing)	≤ 55				

NOTE: ⁽¹⁾ Values referred to a new product, measured in laboratory.

The ability to maintain this performance over the time depends on the environmental conditions and the contact' frequency use.

⁽²⁾ Unless specified otherwise, the specified operating time is after contact stabilization (including bounces).

INSULATION

Insulation resistance (at 500Vdc)					
between electrically independent circuits and between this circuits and ground	> 1,000 MΩ				
between open contact	> 1,000 MΩ				
Dielectric strenght					
between electrically independent circuits and ground	2 kV (1 min.)				
between coil and contacts	4 kV (1 min.)				
between adjacent contacts	3.5 kV (1 min.)				
between open contact	2.5 kV (1 min.)				

MECHANICAL SPECIFICATIONS

Mechanical life expectancy	10 ⁷ operations				
Return in release position	through mechanism with counterweight, by gravity, and spring				
Dimensions (mm)	45 x 50 x 86				
Weight (g)	280				

ENVIRONMENTAL CHARACTERISTICS

Operating temperature	-25 ÷ +70°C				
Relative humidity max	Standard: 75%				
Standards	IEC 61810-1, EN 61810-2, EN 61810-3 Type A, EN 50578, RFI TCSSTB SF IS 21 756, FS DI TCSS ST IS 000402A, EN 60695-2-10, EN 61000-4, EN 60529, IEC 60077-2, EN 50155, EN 50121-3-2, IEC 61373, EN 45545-2				

SOCKETS

PAIR160Z03



Front spring connection

PRIR160Z01



Rear spring connection

PECDZ01



PCB connection

PAVXZ01



Front screw connection

MODELS AND TÜV CERTIFICATIONS

The K series relays (RGMZ63X) are certified by TÜV Reheinland for the EN 50578, type N and EN 50205 (IEC 61810-3), type A standards

NOMINAL VOLTAGE	HITACHI RAIL STS MODEL	AMRA MODEL	TÜV RHEINLAND CERTIFICATIONS EN 50578, TYPE N	TÜV RHEINLAND CERTIFICATIONS EN 50205 (IEC 61810-3), TYPE A
12 VDC	KB1004 (A-V)	RGMZ63X-C012-AV	AK 60126756 0001	AK 50324000 0001
24 VDC	KC1004 (A-P)	RGMZ63X-C024-AP	AK 60126678 0001	AK 60088600 0001
48 VDC	KD1004 (A-R)	RGMZ63X-C048-AR	AK 60127145 0001	AK 50324000 0003
110 / 132 VDC	KE2004 (A-S)	RGMZ63X-C110/132-AS	AK 60127146 0001	AK 50324000 0004
55 VDC	KF1004 (A-T)	RGMZ63X-C055-AT	not certified by TÜV RHEINLAND	

(EN 50205: has been replaced by IEC 61810-3, both standards are equivalent)

EN 50578 COMPLIANCE

The K series relays (model **RGMZ63X**) are classified as **type N**, according to the criteria of the **EN 50578 standard**. Intrinsically, the best that shall be designed and achievable on the subject.

- **Relay type N (“non-proven” relay):** the relay themselves fulfilling all the safety conditions without the aid of other relay or without control of operations in the circuit
- The logic that governs the processes (relay matrix or microprocessor) could refrain from re-reading their status

By way of further quality and safety certification for users, the K series relays (model RGMZ63X) **are certified by TÜV RHEINLAND laboratories:**

- EN 50578, type N
- EN 50205 (now IEC 61810-3), type A

The high insulation levels allow to limit the propagation of induced lightning strikes, keeping segregated, for functional safety purposes, different parts of the system, thus avoiding unwanted intrusiveness phenomena.

EFFICIENT MAGNETIC CIRCUIT

Drop out is ensured by two parallel systems: a return spring and **the force of gravity by means of a counterweight**.

In the event of spring breaking, gravity is sufficient to return the relay back to release condition with the same ohmic quality of the contact.

The spring is housed in a casing. In a remote event of spring breakage (in one or more points), this prevents from any segment interfere with the relay mechanics and from conductive bridges between contacts.

The double restraint, spring & gravity, makes the relay particularly sturdy to vibrations and therefore suitable for critical environments such as on board trains or in cabins along the tracks (interfaces to the block).

IEC 61810-3 COMPLIANCE

In relays with forcibly guided (mechanically linked) or weld-no-transfer contacts, special design and constructional measures are used to prevent that any make (normally-open) contact(s) and any break (normally-closed) contact(s) being in the closed position simultaneously.

- If any break contact fails to open when relay is energized, no make contact shall close, maintaining a contact gap ≥ 0.5 mm
- If any make contact fails to open when relay is de-energized, no break contact shall close, maintaining a contact gap ≥ 0.5 mm

IEC 61810-3 standard defines two types of relay with forcibly guided contacts:

- Type A: Relay whose contacts are **all mechanically linked (forcibly guided)**.
- Type B: Relay containing mechanically linked contacts and contacts which are not mechanically linked.

In the case of relays that include changeover contacts, either the make circuit or the break circuit of a changeover contact can be considered to meet the requirements of this standard.

K series relays are of “Type A”.

PRODUCT DESIGN

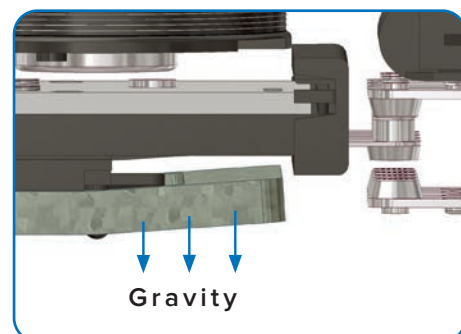

The K series relays (**RGMZ63X**) were born from the union of the expertise of **HITACHI RAIL STS** and **AMRA**.

WELD-RESISTANT CONTACTS

Contacts are “weld-resistant”, suitable to manage currents up to 10 A or up to 8 A (nominal current) simultaneously on all contacts; the maximum breaking voltage is 400 VAC.

The “**weld-resistant**” feature is verified by two specific tests:

1. With established contacts, at the flow of a very high current value. The test is performed both on brake (NC) contacts and on make (NO) contacts
 - Induced lightning current, type 8/20 μ s, **3,000 A**, according to CEI EN61000-4-5
2. Closing a pure capacitive load, on make (NO) contacts as per standard RFI ST IS 758 A.
The heavy and sudden capacitor discharge generates a very high current with high energy content.
 - Load: 500 μ F capacitor, 500 VDC charge
 - Test performed: 10 reps, every 30 seconds
 - Detected peak current: **15,900 A**, for 65 μ s

ROLLING STOCK APPLICATIONS

Relays are suitable also for **ROLLING STOCK** applications and tested as per applicable standards:

- EN 50155 (Railway applications - Electronic equipment used on rolling stock)
- IEC 61373 (Railway applications - Rolling stock equipment)

Shock and vibration tests):

- o Category 1, class B
- EN45545-2 (Railway applications - Fire protection on railway vehicles - Part 2: Requirements for fire behavior of materials and components):
 - o Hazard level 3

On railway vehicles, DC power supply can be derived from a floating potential battery.

For **RGMZ63X / K** series relays:

- The maximum continuous operating voltage allowed is **1.25 Un** for the entire allowed temperature range.
- The minimum pick-up voltage differs from the standard requirements. As for all electromechanical relays, this value depends on coil pre-energization voltage value and on operating ambient temperature.

The minimum pick-up voltage of **RGMZ63X / K** series relays is a consequence of design choices that guarantee in priority the overall performance envisaged by EN 50578 standard, type N relay, and by the FS - RFI TCSSTB SF IS 21 756A standard, in particular the release ratio “k” (≥ 0.6 ; ratio between the release voltage and the pick-up voltage).

When the power supply is switched off, relay is released even in the presence of any parasitic voltages of up to 60% of the relay pick-up voltage in the operating conditions.

LOWER COSTS AND VOLUMES

Costs and volumes are reduced if compared to relays of the same category.

Usually, in railway applications, signaling and safety relays with high numbers of contacts and considerable dimensions are used. The quantity of contacts is widely justified since they are necessary for the realization of the traditional systems logics (electromechanical interlocking).

However, in some specific applications, such as remote control interface, locking systems interface or Automatic Train Control (ATC), a few contacts are sufficient to meet the circuit conditions. Based on these requirements RGMZ63X has fewer contacts, is more compact and less expensive.

The reduced weight and volume ensures excellent behavior even during shock and vibration tests.





SOCKETS

		FRONT connection		REAR connection		
Terminal type		Screw	Spring clamp	Spring clamp	Double Faston	Solder
Mounting		Din Rail Plate	Din Rail Plate	Flush Mounting	Flush Mounting	PCB-mounting
Relay model	Contacts number	Socket model				
BIPOKS	4	48BIP20-I DIN	PAIR160	PRIR160	ADF2	65
MOK-V2	2					
OKBA	4					
OKTA	4					
OKUIC	4					
POKS	2	50IP20-I DIN	PAIR080	PRIR080	ADF1	65 ⁽²⁾
QUADRIPOKS	8	96IP20	PAIR320	PRIR320	ADF4	65 ⁽¹⁾
RCG	2	50IP20-I DIN	PAIR080	PRIR080	ADF1	65 ⁽²⁾
RDG	4	48BIP20-I DIN	PAIR160	PRIR160	ADF2	65
RGG	4					
RGK	4					
RGMZ63X	4	PAVXZ01 ⁽³⁾	PAIR160Z03	PRIR160Z01	-	PECDZ01
RMBX	8	96IP20	PAIR320	PRIR320	ADF4	-
RMGX	8					-
RMMX	8					-
TMS	4	48BIP20-I DIN	PAIR160	PRIR160	ADF2	65
TMM	4					
TRIPOKS	6	78BIP20-I DIN	PAIR240	PRIR240	ADF3	-
UTM	-	48BIP20-I DIN	PAIR160	PRIR160	ADF2	65

(1) use n.2 pcs of sockets for each relays - (2) suitable for mounting 2 relays side by side - (3) not suitable for rolling stock

TYPE OF CONNECTIONS





AMRA and Chauvin Arnoux, 130 years
of history in their own sectors.

The energy of experience makes us move
towards the future.



*RELAY*bility

www.amra-chauvin-arnoux.it



RELAY**ility**



AMRA SpA
Chauvin Arnoux Group

(DESIGN & PRODUCTION SITE)

Via Sant'Ambrogio, 23/25
20846 Macherio (MB)
Tel. +39 039 2457545

ITALY

info@amra-chauvin-arnoux.it



Chauvin Arnoux

(GROUP HQ)

12-16, Rue Sarah Bernhardt
92600 Asnières-Sur-Seine
Tel. +33 144 854485

info@chauvin-arnoux.fr
www.chauvin-arnoux.fr



Intertek

GROUP SUBSIDIARIES

AUSTRIA

Chauvin Arnoux Ges.m.b.H.
Gastgebgsasse 27
A-1230 WIEN
Tel.: (0043) 1 61 61 9 61
Fax: (0043) 1 61 61 9 61 61
vie-office@chauvin-arnoux.at
www.chauvin-arnoux.at

CHINA

Shangai Pujiang
Enerdis Instruments Co. Ltd
n°381 Xian De Road
3rd Floor, Building 1
200081 SHANGHAI
Tel.: (0086) 21 65 21 51 96
Fax: (0086) 21 65 21 61 07
info@chauvin-arnoux.com.cn

GERMANY

Chauvin Arnoux GmbH
Ohmstrasse, 1
77694 KELH / RHEIN
Tel: (0049) 7851 99 26 0
Fax: (0049) 7851 99 26 60
info@chauvin-arnoux.de
www.chauvin-arnoux.de

UNITED KINGDOM

Chauvin Arnoux Ltd
Unit 1 Nelson Ct, Flagship Sq
Shaw Cross Business Park, Dewsbury
West Yorkshire - WF12 7TH
Tel.: (0044) 1924 460 494
Fax: (0044) 1924 455 328
info@chauvin-arnoux.co.uk
www.chauvin-arnoux.com

MIDDLE EAST

Chauvin Arnoux Middle East
PO Box 60-154
1241 2020 JAL EL DIB
BEIRUT (LIBANO)
Tel.: (00961) 1 890 425
Fax: (00961) 1 890 424
camie@chauvin-arnoux.com

SPAIN

Chauvin Arnoux Ibérica S.A.
C/ Roger de Flor N° 293 - 1a Planta
08025 BARCELONA
Tel.: (0034) 902 20 22 26
Fax: (0034) 934 59 14 43
info@chauvin-arnoux.es
www.chauvin-arnoux.es

SWEDEN

CA Mätssystem AB
Sjöflygvägen, 35
SE 18362 TÄBY (Svezia)
Tel.: (0046) 8 50 52 68 00
Fax: (0046) 8 50 52 68 10
info@camatsystem.com
www.camatsystem.com

SWITZERLAND

Chauvin Arnoux AG
Moosacherstrasse 15
CH 8804 AU / ZH
Tel.: (0041) 44 727 75 55
Fax: (0041) 44 727 75 56
info@chauvin-arnoux.ch
www.chauvin-arnoux.ch

USA

Chauvin Arnoux Inc
d.b.a. AEMC Instruments
15 Faraday Drive
Dover - NH 03820
Tel.: (001) 800 945 2362
Fax: (001) 603 742 2346
sales@aemc.com
www.aemc.com